



Press Conference Stuttgart 2008



© 2003-2008 MVTec Software GmbH

1

MVTec Software GmbH is a leading international manufacturer of software for machine vision used in all demanding areas of imaging: semi-conductor industry, web inspection, quality control and inspection applications in general, medicine, surveillance etc.

MVTec's innovative work is driven by a commitment to be the number one supplier for sophisticated technologies in machine vision. MVTec is engaged in sponsoring various activities in universities, thus participating in the challenging process of understanding how machines can be taught to see.

HALCON is the comprehensive standard software library with an integrated development environment (IDE) for machine vision that is used worldwide.

HALCON provides an extensive library of more than 1300 operators with outstanding performance for blob analysis, morphology, pattern matching, measuring, 3D object recognition, and binocular stereo vision, to name just a few.

ActivisionTools is the outstanding result of MVTec's expert knowledge in machine vision: a quick and efficient application creator with an easy-to-use graphical interface.

MVTec is committed to machine vision software: building vision for business

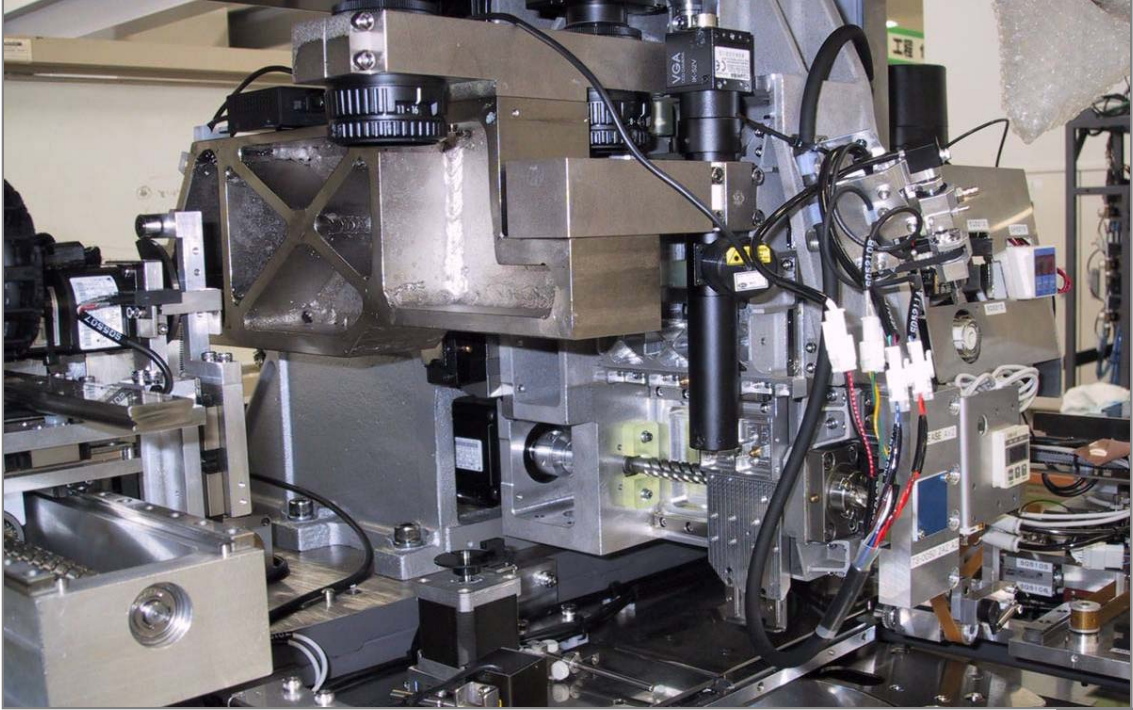

2

MVTec's vision is straightforward:

- Market leadership in technology for machine vision software
- Unique competence center for image processing algorithms
- Manufacturer of world-wide standard-software products for the machine vision industry

MVTec's distribution channels are a mirror of the globalized world

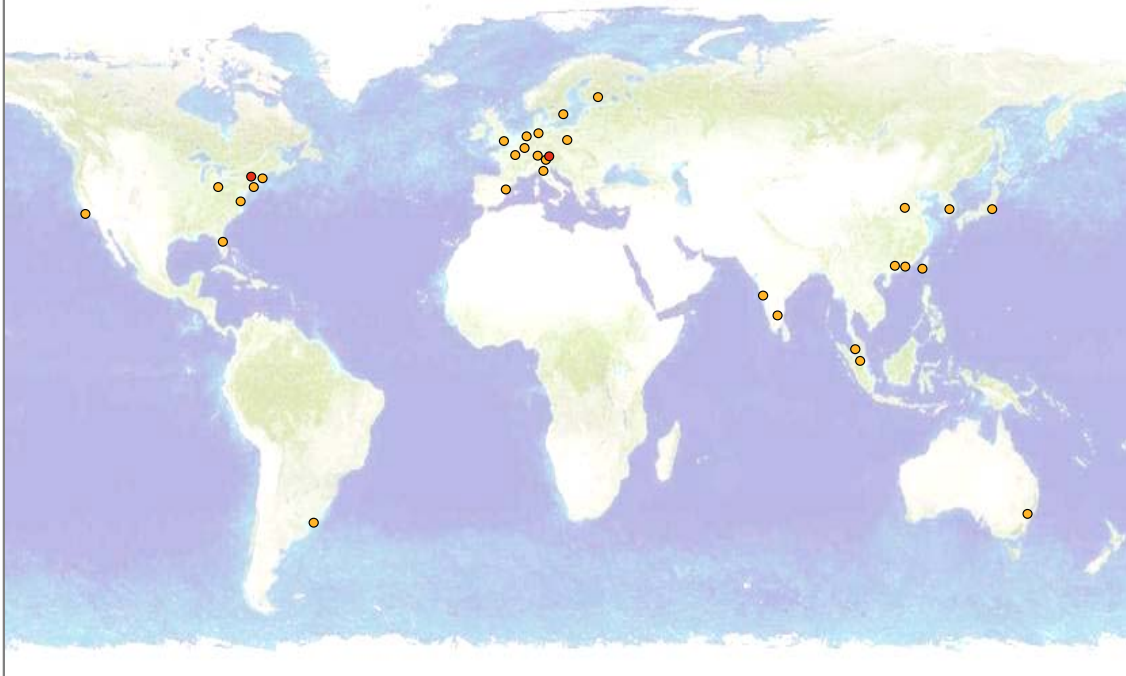

3

MVTec aims at a comprehensive market penetration and to successfully opening and exploiting international emerging markets. MVTec's products are distributed via highly qualified and trained local distribution partners.

Globalization is both a challenge and a chance for the machine vision industry



The current downturn of the economy due to the financial crises may effect the machine vision industry. However, the regional effect are different. The machine vision industry in Europe and North America is more dependent on the automotive industry than in Asia. In Asia and to a certain extent in North America the industry is more dependent on semiconductor and electrical industries than in Europe.

This view only covers existing markets and tries to estimate growth from an established market perspective. This is shortsighted. Machine vision is on its core level a technology providing industry serving many markets. Yet, not all markets have been explored. Yet, not all technologies have been discovered which can contribute to these markets. Growth rates estimate have to freed from the old economy perspective: the quarterly reports of the stock exchanges around the world.

Standard-software means integration efforts for customers

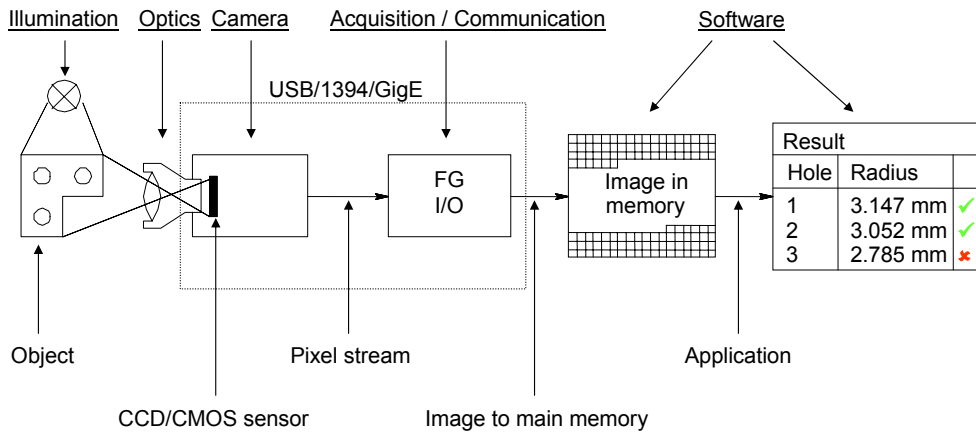

MVTec is committed to recognize customers requirements and improving customer satisfaction. Standard-software for machine vision has to ensure an easy integration of the components within a short period of time to quickly build an application. Thus, image acquisition has been addressed by MVTec since its foundation back in 1996.

MVTec hosts the largest image acquisition partner program in the machine vision industry

 ABS	 Allied Vision	 Basler	 Baumer
 BitFlow	 Daheng	 Festo	 IDS
 JAI	 Leutron	 LinX	 Lumenera
 Mikrotron	 NET	 Opteon	 Photonfocus
 Pleora	 Point Grey	 Prosilica	 Sick IVP
 Silicon Software	 SVS-Vistek	 Tattile	 The Imaging Source
 VRmagic			

MVTec Image Acquisition Partner Program

Know to the community since many years:

- Support of more than 60 different image acquisition devices from more than 30 manufacturers or organizations
- Instant support of all commonly used cameras in machine vision, e.g. analog, Camera Link, USB 2.0, IEEE 1394, and GigE cameras

MVTec initially introduced the Image Acquisition Partner Program which is now running for one year:

- Motivation: customers requests for a hassle-free integration of machine vision soft- and hardware
- Idea: maximum compatibility between MVTec's standard software products and partner's image acquisition devices
- More than 25 partners in the program – the Star Alliance of the machine vision industry

Have a look at the revised web page <http://www.halcon.com/image-acquisition>

The book Machine Vision Algorithms and Applications is a big success



Having accumulated knowledge about machine vision algorithms for many years the book Machine Vision Algorithms and Applications written by employees of MVTec is intended to share our technical expertise with an increasingly better educated audience. Published late 2007 the book is a big success. Wiley printed the 2nd edition, a Japanese version has been published in June this year and a bilingual simplified Chinese version will be published by the end of this year.

Inventing technology in house is a key factor for driving MVTec further



8

During the last years, machine vision has established its place primarily in the automation industry. Traditional fields, such as production control or quality control, are supplemented by many further application areas. For example, thanks to HALCON's latest 3D technology, machine vision nowadays is successfully implemented more and more in the area of robotics. MVTec invents and develops technology in house at its headquarters in Munich.

HALCON meets customer's requirements

Technology
Speed
Usability

HALCON fulfills all needs a modern machine vision application request.

HALCON offers an extremely wide range of sophisticated software technologies for virtually all application areas and is therefore a technological leader in many fields.

Besides functionality, speed is of extreme importance to be competitive in the fast developing vision market.

The integrated development environment – especially designed for the needs of machine vision – allows a fast but still extremely flexible way of application development. Various tools offer a quick and informative inspection of image data, regions, and contours. Assistants offer complex functionality in a easy to handle manner and thus significantly reduce the development time.

HALCON provides leading technologies

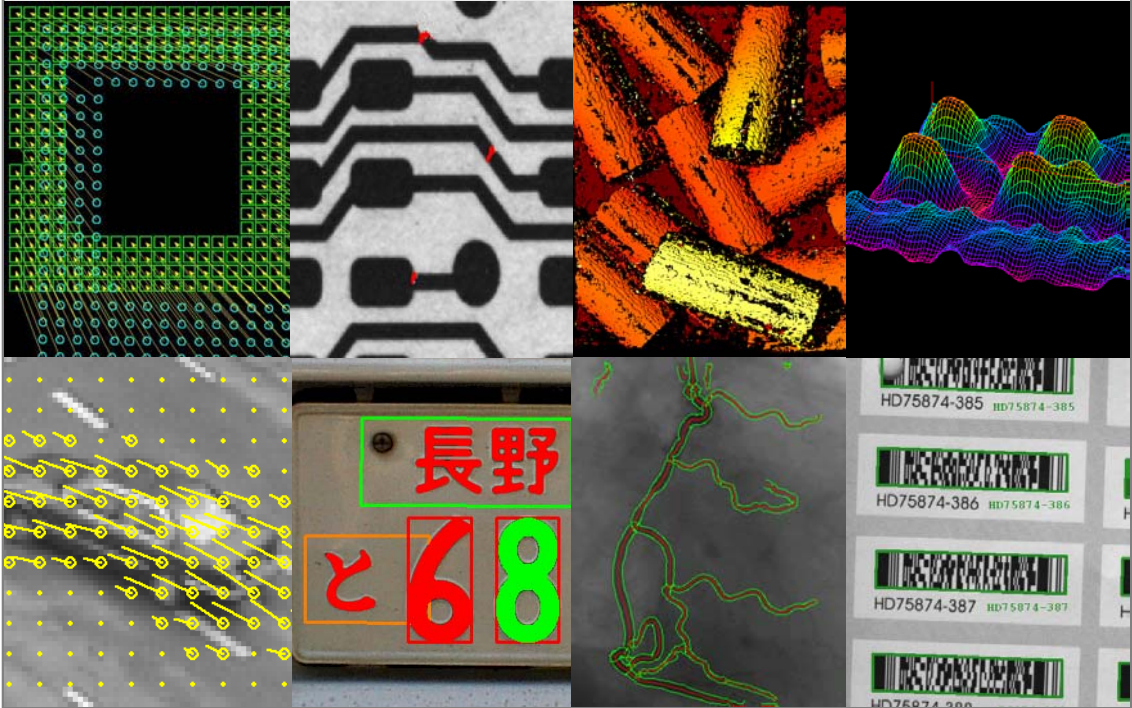

10

These pictures show just a few of the many useful technologies in HALCON – many of which are hard to find in other libraries: arbitrarily shape ROIS for highest flexibility and speed, subpixel accurate edge and line extraction even with color images, subpixel precise morphology, component-based matching, many 3D technologies, e.g., multigrid stereo or 3D matching, depth from focus, optical flow, OCR with a wide range of pre-trained fonts, or powerful classifiers based all multiple state of the art technologies.

The unique matching tools meet the demands of many applications

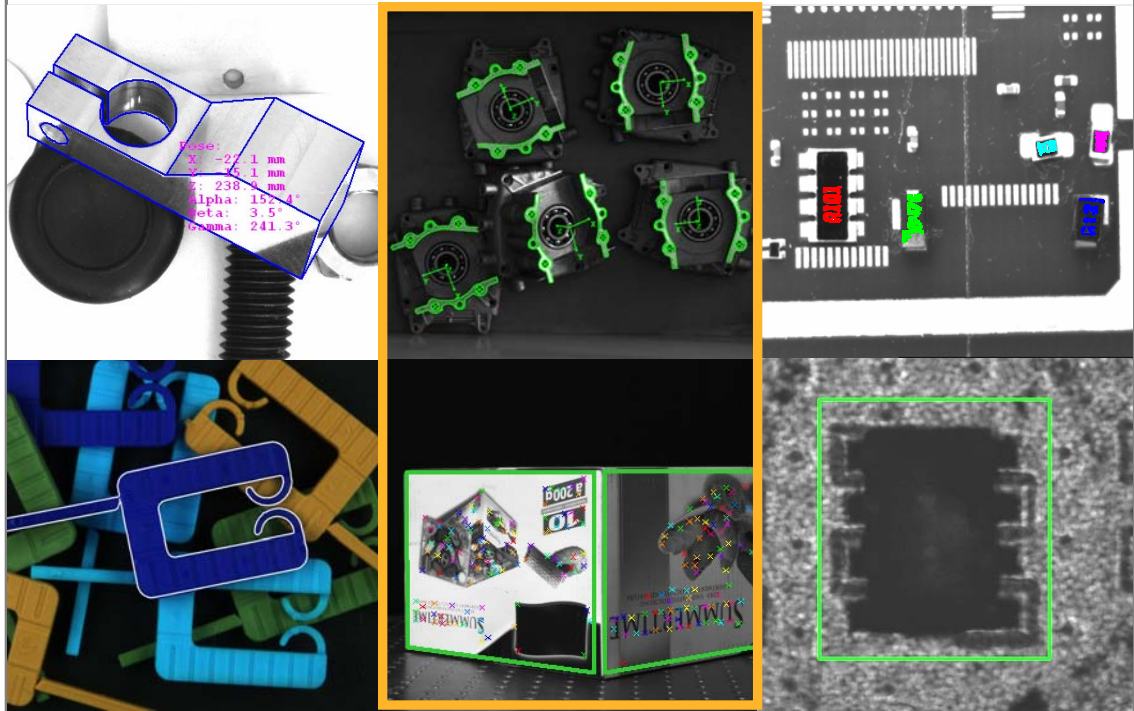

11

Besides other technologies HALCON offers a wide range of highly sophisticated matching technologies. HALCON allows to locate objects with arbitrary orientation in 3D (3D alignment), the well established shape-based matching – working even with color images, the unique component based matching and the well proven normalized cross correlation.

New in HALCON 9.0 are two more matching technologies which can be used for 3D alignment:

- *Descriptor-based matching.* This revolutionary new matching technology is able to find perspectively distorted objects. It is based on the detection of interest points where gray values are clearly differentiated from neighboring areas (brightness, curvature, corners, spots).
- *Perspective, deformable matching.* This new matching technology is also able to match perspectively distorted objects. In contrast to the descriptor-based matching, the perspective, deformable matching is edge-based (like HALCON's shape-based matching) and thus can best be used with objects with clearly distinguishable edges.

HALCON supports the entire range of today's 3D technologies

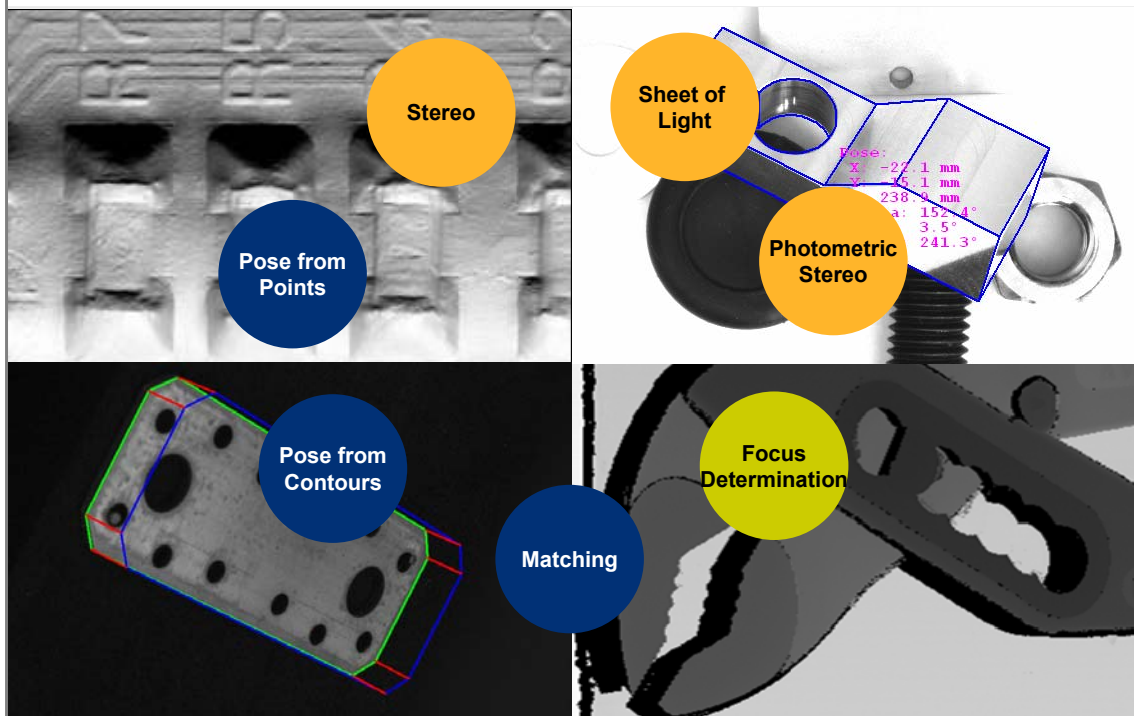

Especially for robotics, machine vision becomes more and more important. In addition to established 3D technologies such as 3D object recognition, 3D camera calibration, binocular stereo reconstruction, and depth from focus, HALCON 9.0 again extends its large set of 3D operators with new methods like multigrid stereo, sheet-of-light measurement, descriptor-based matching and perspective, deformable matching.

HALCON includes automatic operator parallelization (AOP) since the year 2000

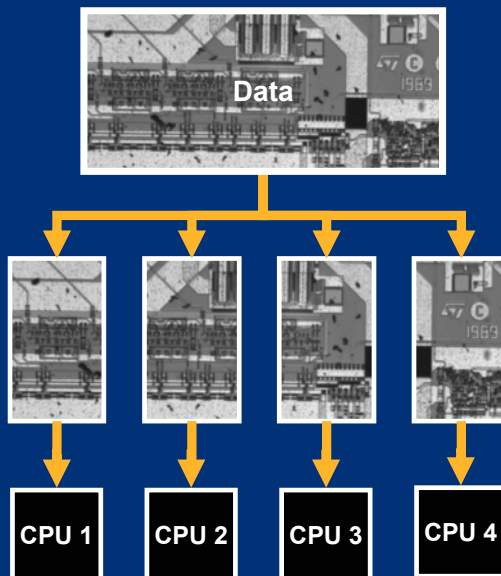

Since its version 6.0 in the year 2000, the software library HALCON is able to parallelize threads operators automatically. That was MVTec's early answer to the first multi-processor machines at this time. The development of HALCON's parallelization started even before the vision market was fully aware of it.

HALCON provides Automatic Operator Parallelization (AOP): The programmer has to do nothing to make use of it. HALCON's AOP automatically detects the number of available CPUs. Then, HALCON automatically splits, e.g., an image into the according number of logical subimages, passes these on to the processing threads, and after processing automatically combines them to the resulting image. This happens of course efficiently: without extra copying of image data.

Automatic parallelization speedup depends on the operator

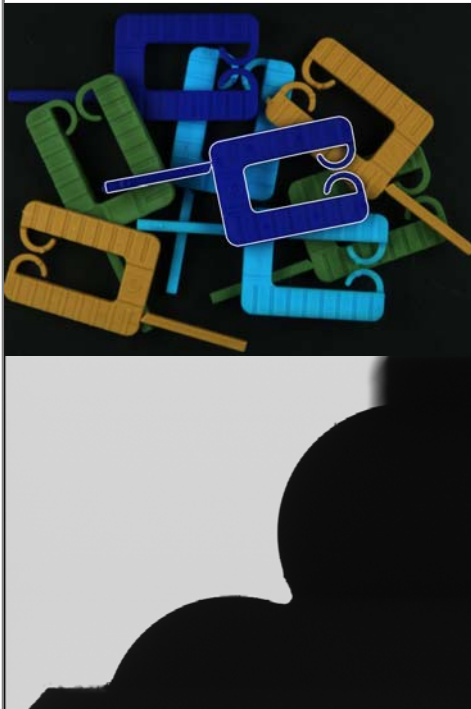

Speedup factor

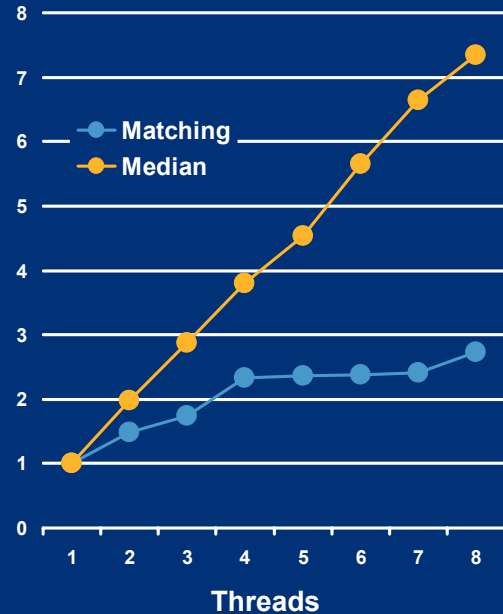

The benchmarks for shape-based matching show that with automatic operator parallelization a significant speedup can be achieved on multicore systems. Due to the fact, that shape-based matching includes sequential parts and has a high memory throughput, the speedup increase is slower for a high number of cores. In contrast, the median filter can be parallelized in a quite straight forward way. This results in linearly increasing speedup factors and only very small overhead. Table of speedup factors (2x Intel QuadCore 2,3 GHz):

Threads	1	2	3	4	5	6	7	8
Matching	1	1.5	1.7	2.3	2.4	2.4	2.4	2.7
Median 5x5	1	2	2.9	3.8	4.5	5.7	6.6	7.3

HALCON meets customer's requirements



Technology



Speed

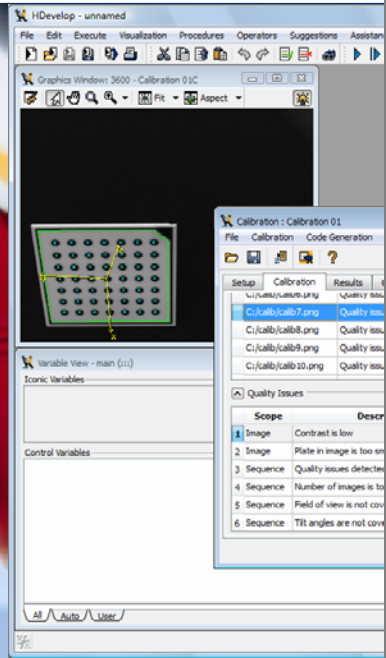

Usability

Come and visit us in hall 4 booth C55

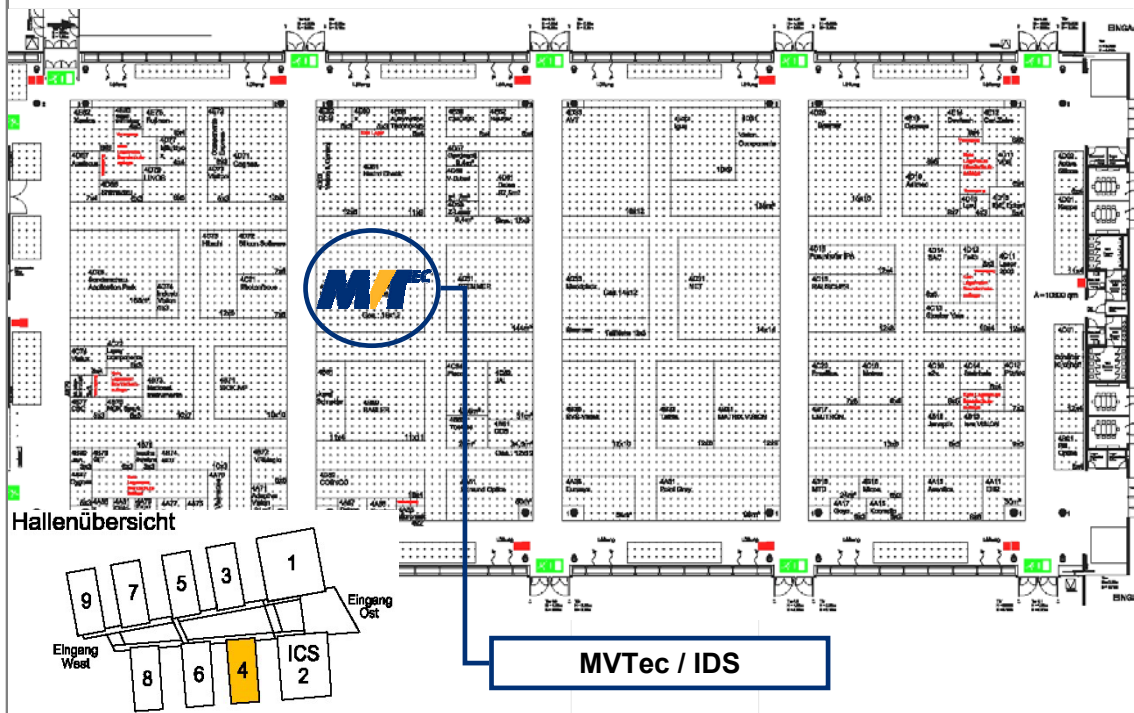

At MVTec's booth we have a lot of exciting demos and presentations on display.

Helga – MVTec's robot performs an interactive 3D matching demo by using a single camera only.

Bigger is better – HALCON processes images taken by a line scan camera larger than 32K x 32K.

Usability – Users can develop machine vision solutions faster than ever.